

R-22 WALL CONFIGURATION		
NOMINAL CONC. WIDTH - TIE SIZE	WALL WIDTH W	WALL CAVITY C
4" (100mm)	8 $\frac{1}{4}$ " (210mm)	3 $\frac{3}{4}$ " (96mm)
6" (150mm)	10 $\frac{1}{4}$ " (260mm)	5 $\frac{3}{4}$ " (146mm)
8" (200mm)	12 $\frac{1}{4}$ " (311mm)	7 $\frac{3}{4}$ " (197mm)
10" (250mm)	14 $\frac{1}{4}$ " (362mm)	9 $\frac{3}{4}$ " (248mm)
12" (300mm)	16 $\frac{1}{4}$ " (413mm)	11 $\frac{3}{4}$ " (299mm)

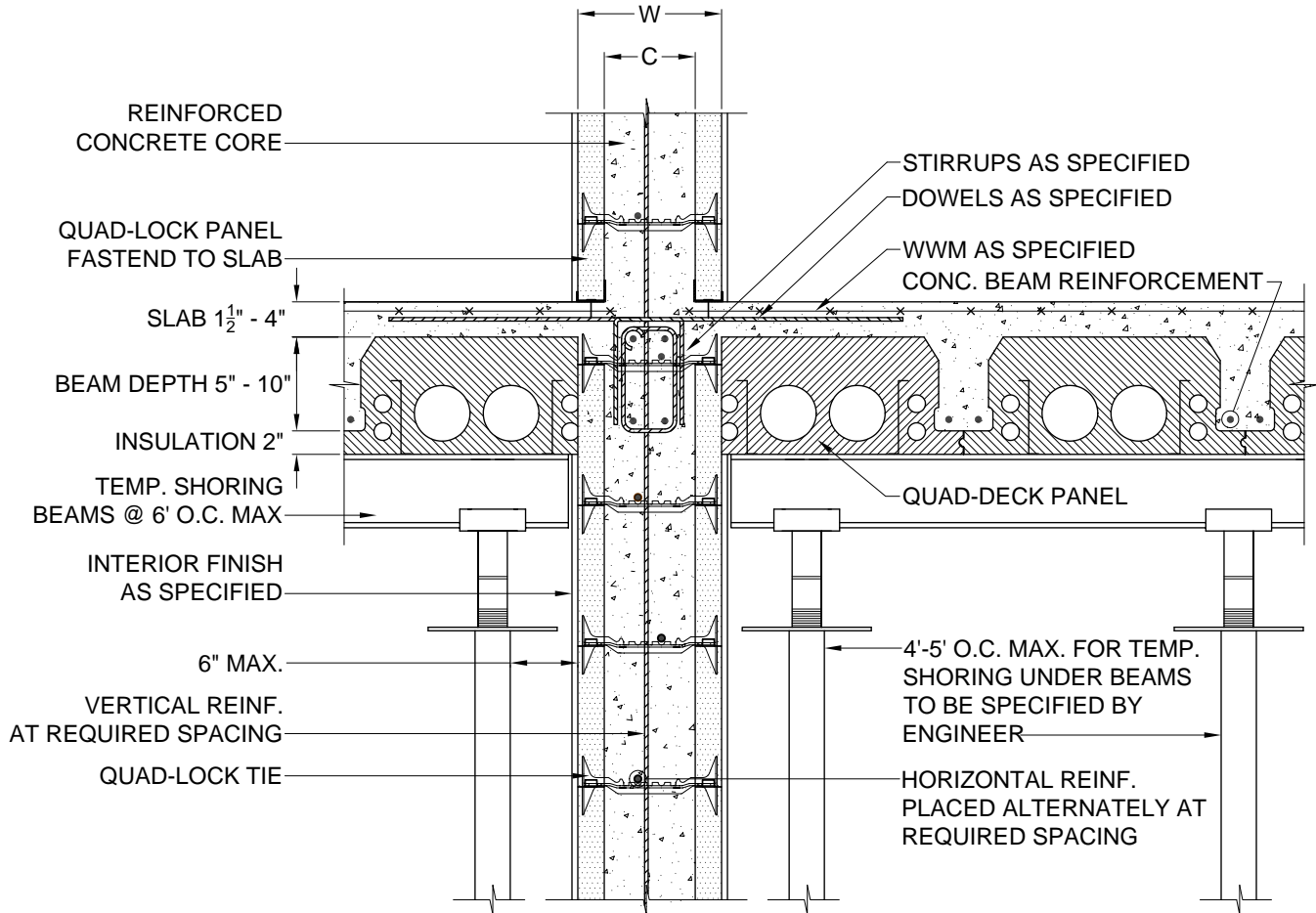

1
4.4
**CONNECTION DETAIL**  
 3/4" = 1'

# QUAD-LOCK<sup>®</sup> BUILDING SYSTEMS

Quad-Lock Building Systems Ltd.  
 7398 - 132nd Street  
 Surrey, BC V3W 4M7  
 Canada

888.711.5625 - Toll Free  
 604.590.3111  
 604.590.8412 - fax  
 www.quadlock.com

## QUAD-DECK FLOOR SYSTEM INTERNAL BEARING WALL JOIST PARALLEL

DATE:	2005-07-23	SCALE:	3/4" = 1'-0"
REVISION NO.:	R-03	PROJECT:	N/A
REVISION DATE:	2005-08-24	CUSTOMER:	N/A
DRAWN BY:	Z. PROSTRAN	APPROVED BY:	D. J. BENNION
			<b>4.4</b>

DUE TO VARIANCES IN LOCAL CODES, CONSTRUCTION PRACTICES AND REQUIREMENTS ALL DETAILS SHALL BE CONSTRUCTED IN ACCORDANCE WITH SUCH LOCAL CODES, CONSTRUCTION PRACTICES, AND REQUIREMENTS REGARDLESS OF CONSTRUCTION DETAIL SHOWN IN DRAWING. QUAD-LOCK BUILDING SYSTEMS LTD. RESERVES THE RIGHT TO CHANGE INFORMATION SHOWN WITHOUT NOTICE.